

[Request Information](#)
[Permalink](#)

SYSTEM AND METHOD FOR SENSING VOLATILE ORGANIC COMPOUNDS

Tech ID: 33368 / UC Case 2019-200-0

BACKGROUND

Volatile organic compounds (VOCs) are released by various products and during various processes. Ethanol is one such VOC that is released as an important byproduct of alcoholic fermentation. Ethanol emitted during fermentation can be estimated using the amount of liquid lost during storage. The instrumentation needed to accurately quantify ethanol emissions is specialized and costly. Researchers at UC Santa Cruz have developed low-cost VOC sensors that are useful for the wine industry, among others.

TECHNOLOGY DESCRIPTION

This patented technology involves sensors that rely on the semiconductive properties of metal oxide nanostructures. A substrate is coated with a conductive coating, and a channel is carved into the conductive coating. Metal oxide nanostructures are deposited into the channel. The resistance of the metal oxide nanostructure layer varies in response to contact with the VOC, and is indicative of VOC concentration. The sensor is used with an ultraviolet light source which stimulates and cleans an active surface of the sensor.

This sensor is a low-cost alternative to conventional VOC sensors and is sensitive to compounds of interest. The sensor is not affected by moisture, and operates at ambient temperature.

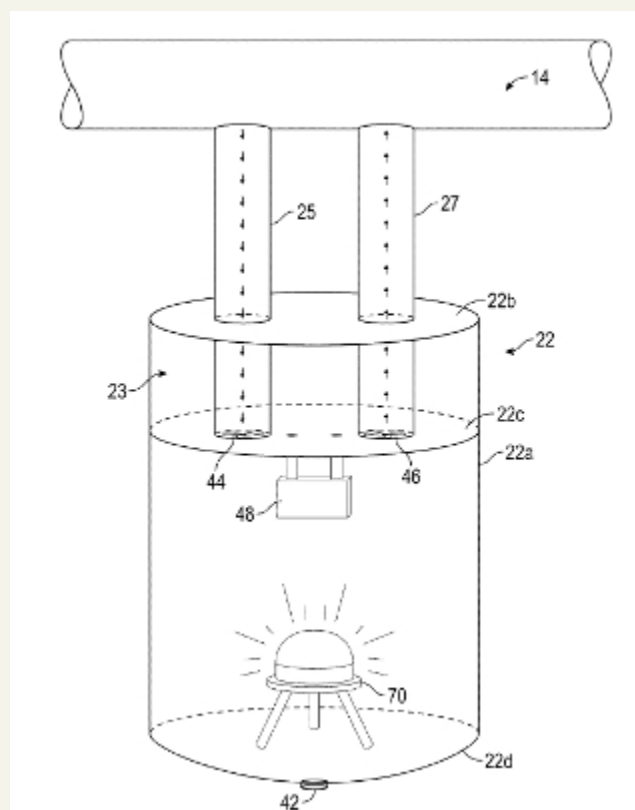

APPLICATIONS

- ▶ measuring VOCs released during alcoholic fermentation
- ▶ measuring VOCs released during composting
- ▶ emissions control

ADVANTAGES

- ▶ operates at ambient temperature
- ▶ not adversely affected by moisture

CONTACT

Jeff M. Jackson
jjackso6@ucsc.edu
 tel: .



INVENTORS

- ▶ Rojas-Andrade, Mauricio
- ▶ Weiss, Peter

OTHER INFORMATION

KEYWORDS

volatile organic compound, ethanol, wine, sensor, nanoparticle, fermentation, brewing, distillation, environmental sensor, alcohol sensor, ethanol sensor

CATEGORIZED AS

- ▶ **Environment**
 - ▶ Sensing
- ▶ **Materials & Chemicals**
 - ▶ Nanomaterials
- ▶ **Semiconductors**
 - ▶ Other
- ▶ **Sensors & Instrumentation**
 - ▶ Environmental Sensors
 - ▶ Other
 - ▶ Process Control

RELATED CASES

2019-200-0

- ▶ low cost
- ▶ sensitive to relevant industry compounds and concentrations

INTELLECTUAL PROPERTY INFORMATION

Country	Type	Number	Dated	Case
United States Of America	Issued Patent	11,680,934	06/20/2023	2019-200

Additional Patent Pending

University of California, Santa Cruz
Industry Alliances & Technology Commercialization
Kerr 413 / IATC,
Santa Cruz, CA 95064

Tel: 831.459.5415
innovation@ucsc.edu
officeofresearch.ucsc.edu/
Fax: 831.459.1658

© 2023, The Regents of the University of California
[Terms of use](#)
[Privacy Notice](#)